



上海松铭传动机械有限公司
SHANGHAI SONGMING TRANSMISSION MACHINERY CO.,LTD



公司简介 | Company brief introduction

上海松铭传动机械有限公司是一家研究、设计、销售机械传动类产品的公司，供应产品有：WS/WSD/WSS/WSP万向节、SWP/SWC万向联轴器、ML梅花弹性联轴器、XL/XLD星型弹性联轴器、DJM/JMII/SJM/JMIIJ/ZJM弹性膜片联轴器、TL弹性柱销套联轴器、HL弹性柱销联轴器、ZL柱销齿式联轴器、制动轮式联轴器、铝合金联轴器、UL/LLA/LLB轮胎联轴器、SL十字滑块联轴器，KC/GL链条联轴器、JS蛇型弹簧联轴器、鼓型齿联轴器、凸缘联轴器、JQ夹壳联轴器、WH/SL滑块联轴器、联轴器配件（弹性体/轮胎体/铝合金外罩壳/联轴器膜片组/联轴器弹簧等）、Z型胀紧联结套及SPA/SPB/SPC/SPZ锥套皮带轮等产品，并承接非标传动零部件的定制加工。

产品咨询订购电话：18621008099

联轴器系列



联轴器系列



XL型星形弹性联轴器
XL star type elastic Shaft coupling



◇特点

- 星形联轴器以工程塑料或聚氨酯为弹性元件，具有缓冲，减振，耐磨等特点，拆装方便，工作温度 $-20^{\circ}\text{C} \pm 80^{\circ}\text{C}$ 。
- 弹性体凸爪大的凹面，使渐开线齿上的表面压力很小，齿上即使承受过载，齿仍不会磨损或变形。
- 标准的爪型联轴器，爪型表面为曲面设计。
- 轴毂材料为粉末冶金，铸铁，球墨铸铁，钢或铝合金。
- 弹性体为聚胺脂材料，有4种不同的硬度可供选择（80A，90A，98A，64D），分别承受不同扭矩，其中90A为标准型。
- 具有良好的防振性能。
- 具有防油，防尘，防砂，防潮等性能。
- 不同硬度的弹性体用不同的颜色来区分。
- 失效安全运行设计。
- 有多种的轴孔组合。
- 连接方式有键槽，花键，单双槽锁紧，锥形摩擦锁紧等多种方式。
- 有中间加长式，中间脱卸式，标准脱卸式，法兰式等各种变化形式可供选择。
- 可根据客户需求定制。
- 应用于通用机械，水工机械，工程机械，冶金机械，矿山机械，化工机械等多种场合。



XL型星形弹性联轴器
XL star type elastic shaft coupling

◇轴套型式 Forms of shaft sleeve

由于星形弹性联轴器适用于许多不同的应用场合，因此有多种不同的轴套型式以供选择。这些型式最大的不同在于由键定位连接传动或胀紧套的摩擦夹紧力矩传动。

Rotoc apply for many different situation, so there are kinds shaft sleeves for selecting. The differences is driven by keyway oriental connecting or driven by attrion clamp torque of locking devices.

1.0 型式 带键槽和固定螺钉

1.0 Type with keyway and set screw

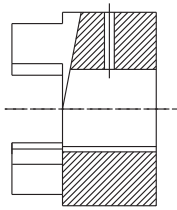

键槽传动，许用力矩取决于键盘框框表面许用压力。适用于要求无齿隙的存在重负荷反转的场合。

Rated torque lies on rated pressure on keyset face. It apply for heavy loading with reverse rotate and without teeth space situation.

1.1 型式 不带键槽，带固定螺钉

1.1 Type with set screw and without keyway

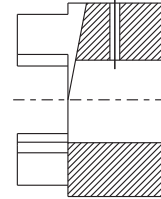

适用于要求无间隙的微小力矩场合。(无防爆性能)

Apply for the situation that small torque driven without clearance. (No explosion-protection performance)

2.0 型式 夹紧式，单槽，不带键槽

2.0 Type Clamp, single trough, no keyway

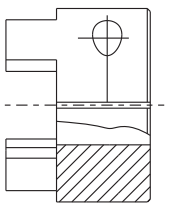

摩擦力夹紧连接传动，轴和轴套连接无间隙。许用力矩取决于轴径。规格XL2以下的联轴器的轴套为此型式。

Connected and driven by clamp of friction, limited torque lies on shaft diameter. This shaft sleeve is fit for the couplings whose specifications is below XL2' S.

2.1 型式 夹紧式，单槽，带键槽

2.1 Type Clamp, single trough, with keyway

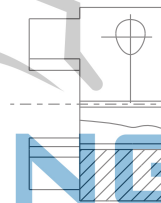

摩擦力夹紧传动，避免或减少了反向间隙及键表面的接触压力，规格XL2以下的为此型式。

Connected and driven by friction, avoid and reduce touch pressure and reversal clearance. It is fit for the couplings whose specifications are below XL2' S.

2.5 型式 夹紧式，双槽，不带键槽

2.5 Type Clamp, double troughs, without keyway

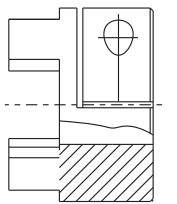

摩擦力夹紧连接传动，轴和轴套连接无间隙。许用力矩取决于轴径。规格XL2以上的联轴器的轴套为此型式。

Connected and driven by friction, there is no clearance between shaft and shaft sleeve. Limited torque lies on shaft diameter. It is fit for the shaft coupling whose specification is above XL2' S.

2.6 型式 夹紧式，双槽，带键槽

2.6 Type Clamp, double troughs, with keyways

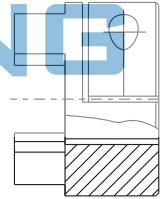

摩擦力夹紧传动，避免或减少了反向间隙及键表面的接触压力，规格XL2以上的为此型式。

Connected and driven by friction, avoid and reduce touch pressure and reversal clearance. It is fit for the shaft coupling whose specification is above XL2' S.

4.0 型式 夹紧式，带KRZ11型胀紧套

4.0 Type Clamp, with KRZ11 locking device

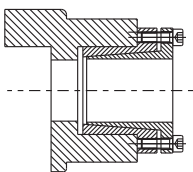

胀紧套连接传动，轴和轴套连接无间隙。适用于更高的扭矩。

Connected and driven by locking devices. There is no clearance between shaft and shaft sleeve. It is fit for higher torques.

5.0 型式 夹紧式，带KLZ2或Z3型胀紧套

5.0 Type Clamp, with KLZ2 or Z3 locking devices

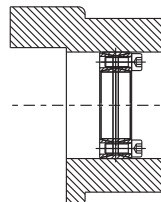

胀紧套连接传动，轴和轴套连接无间隙，适用于更高的扭矩。胀紧套取决于轴径胀紧螺钉可置于内侧或外侧。具体详见胀紧套样本。

Connected and driven by locking devices. There is no clearance. Apply for higher torque. Locking device is lie and shaft diameter set bolts can be place in inner side or outer side.

6.0 型式 胀紧套夹紧式

6.0 Type Clamp, by locking devices

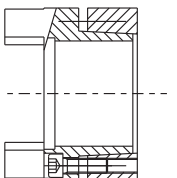

内置胀紧套连接的传动，适用于更高的扭矩，胀紧螺钉置于弹性体侧。

Connected and driven by inner locking devices. Apply for higher torques locking bolts are placed in spider side.

6.5 型式 胀紧套夹紧式

6.5 Type Clamp by locking devices

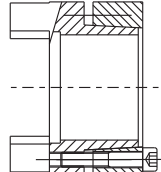

与6.0型式相同，只是螺钉在外侧。例如中间轴的径向拆装。

There is no difference with 6.0 type. It's bolts placed in outer side. For example, assemble and disassemble on axial of middle shaft.

可按客户要求做特殊设计
It can special designed upon requirements of clients.

XL型星形弹性联轴器
XL star type elastic shaft coupling

◇ 标记 Mark

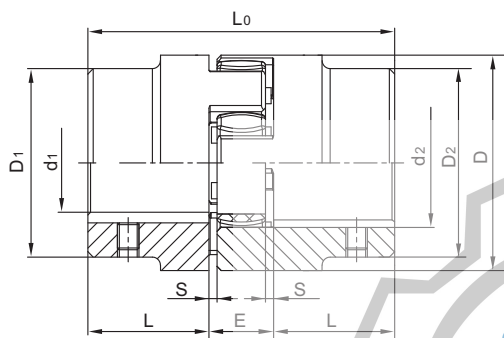
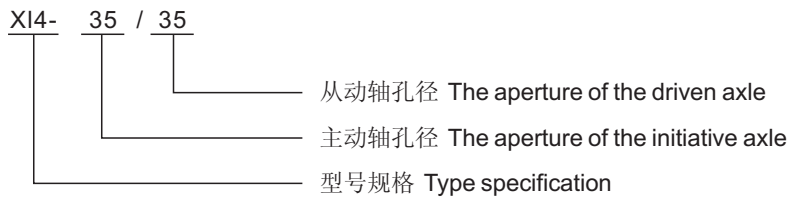

XL 型星形弹性联轴器
XL star type elastic shaft coupling



◇ XL型星形弹性联轴器的基本参数及主要尺寸
Main size and parameters of XL star type elastic shaft coupling

型号 Type	公称扭矩 Nominal torsion N.m	许用转速 Limited rotational speed r/min	轴孔直径 Diameter of the shaft hole d1、d2mm	轴孔长度 Length of the shaft hole L mm	L0 mm	D mm	D1D2 mm	E mm	S mm	转动惯量 Rotate inertia Kg.cm ²	重量 Weight kg
XL0	12.5	19000	6-16	18	50	30	30	13	1.5	0.00005	0.10
XL1	17	19000	6-19	25	66	40	32	16	2	0.00008	0.30
XL2	60	14000	8-24	30	78	55	40	18	2	0.0002	0.61
XL3	160	11800	10-28	35	90	65	48	20	2.5	0.0007	1.00
XL4	325	9500	12-38	45	114	80	66	24	3	0.002	2.08
XL5	450	8000	14-42	50	126	95	75	26	3	0.004	3.21
XL6	525	7100	15-48	56	140	105	85	28	3.5	0.006	4.41
XL7	685	6300	20-55	65	160	120	98	30	4	0.012	6.64
XL8	940	5600	22-65	75	185	135	115	35	4.5	0.025	10.31
XL9	1920	4750	30-75	85	210	160	135	40	5	0.054	16.03
XL10	3600	3750	40-90	100	245	200	160	45	5.5	0.139	27.50
XL11	4950	3350	50-100	110	270	225	180	50	6	0.245	38.50
XL12	7200	3000	60-110	120	295	255	200	50	6.5	0.435	54.0
XL13	10000	2650	60-125	140	340	290	230	60	7	0.85	81.8
XL14	12800	2380	60-140	155	375	320	255	65	7.5	1.4	109.7
XL15	19200	2000	80-160	175	425	370	290	75	9	2.72	162.7
XL16	28000	1800	85-180	195	475	420	325	85	10.5	4.95	230.8

XLD型扩大轴孔星形弹性联轴器
XLD type star elastic shaft coupling with enlarge hole

◇结构特点

- 轴套使用钢件，特别适用于重载荷的传动单元，如升降，轧钢机，建筑机械。
- 本联轴器与XL型相似，较适合于孔径更大的安装场合。
- 标记方法同XL型。
- 设计紧凑，转动惯量小。
- 表中是弹性体的硬度为90shA时的公称扭矩值。

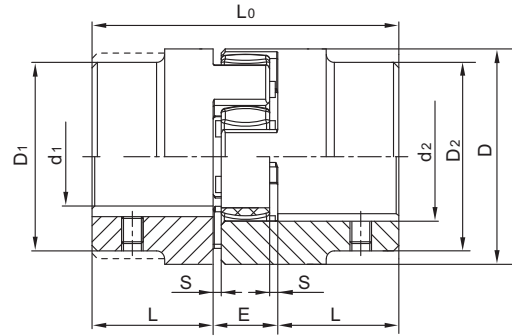

XLD型扩大轴孔星形弹性联轴器
XLD type star elastic shaft coupling with enlarge hole

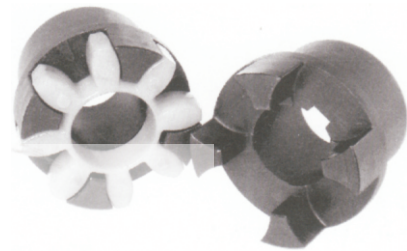

◇XLD型扩大轴孔星形弹性联轴器基本参数和主要尺寸
Base figure and main size of XLD type star elastic shaft coupling with enlarge hole

型号 Type	公称扭矩 Nominal torsion N.m	许用转速 Limited rotational speed r/min	轴孔直径 Diameter of the shaft hole d1、d2mm	轴孔长度 Length of the shaft hole L mm	L0 mm	D mm	D1 (D2) mm	D2 mm	E mm	S mm	转动惯量 Rotate inertia Kg.cm ²	重量 Weight kg
XLD1	17	19000	6-25	25	66	40	32	40	16	2	0.00008	0.328
XLD2	60	14000	8-35	30	78	55	40	55	18	2	0.0003	0.68
XLD3	160	11800	10-40	35	90	65	48	65	20	2.5	0.0007	1.16
XLD4	325	9500	12-48	45	114	80	66	78	24	3	0.002	2.27
XLD5	450	8000	14-55	50	126	95	75	94	26	3	0.005	3.57
XLD6	525	7100	15-60	56	140	105	85	104	28	3.5	0.008	4.80
XLD7	685	6300	20-70	65	160	120	98	118	30	4	0.016	7.87
XLD8	940	5600	22-75	75	185	135	115	134	35	4.5	0.031	10.89
XLD9	1920	4750	30-90	85	210	160	135	158	40	5	0.068	17.73
XLD10	3600	3750	40-100	100	245	200	160	180	45	5.5	0.159	29.60
XLD11	4950	3350	50-110	110	270	225	180	200	50	6	0.277	43.0
XLD12	7200	3000	60-125	120	295	255	200	230	55	6.5	0.51	58.6
XLD13	10000	2650	60-145	140	340	290	230	265	60	7	1.0	88.4
XLD14	12800	2360	60-165	155	375	320	256	300	65	7.5	1.7	120.8
XLD15	19200	2000	80-190	175	425	370	290	345	75	9	3.35	179.1
XLD16	28000	1800	85-220	195	475	420	325	400	85	10.5	6.37	261.0

XL型带法兰星形弹性联轴器
XL type star elastic coupling with flange

◇ 标记 Mark

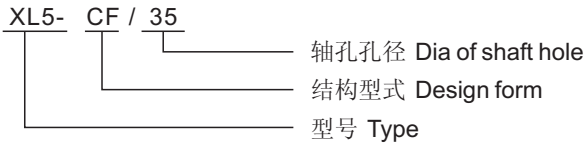

◇ 结构特点

- 适用于重机械的法兰联结。
- CF型和CFN型适用于法兰和轴的联结。
- 双法兰结构DF型和DFN型可以不移动两端设备进行径向安装，可快速更换弹性体。
- CFN型和DFN型的外径较小。
- DFN型可以根据客户的特殊法兰定做。

◇ Design feature

- Apply for flange connect in heavy machine.
- CF and CFN apply for connection between flange and shaft.
- DF and DFN type of flange structure can be installed on radial without moving the equipments on both ends. Spider can be instead under high speed.
- Diameter of CFN and DFN is less than other type.
- DFN type can be especial manufactured accord on the flange provided by client.

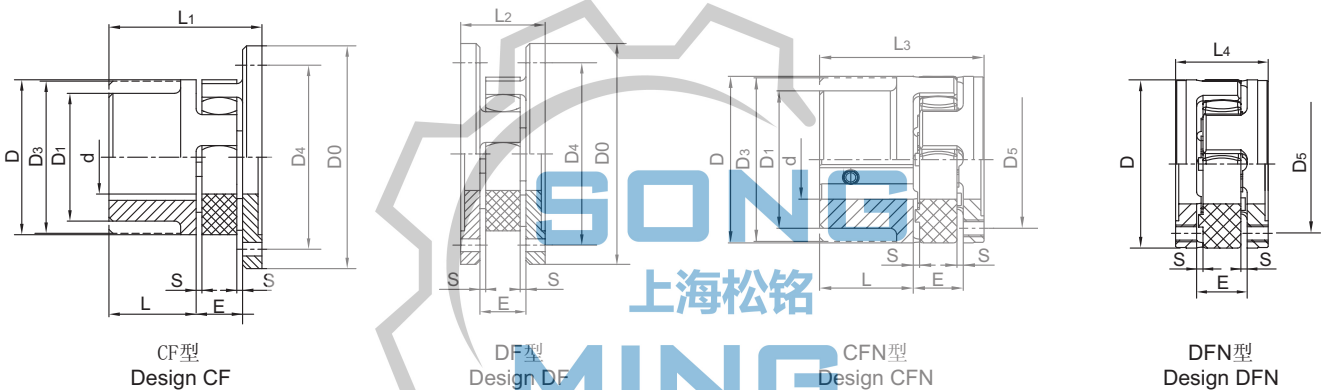

◇ XL带法兰星形弹性联轴器基本参数和主要尺寸

Base figure and main size of XL type star elastic coupling with flange

型号 Type	公称扭矩 Nominal torsion N.m	许用转速 Limited rotational speed r/min	轴孔直径 Diameter of the shaft hole d1、d2mm	轴孔长度 Length of the shaft hole L mm	D	D0	D1	D3	E	S	L1 (L3)	L2 (L4)	D4	D5	联接 螺栓 Connec- ting bolt
					(mm)								(mm)		
XL2	60	14000	8~35	30	55	80	40	55	18	2	56	34	65	45	8-M5
XL3	160	11800	10~40	35	65	100	48	65	20	2.5	65	40	80	54	8-M6
XL4	325	9500	12~48	45	80	115	66	78	24	3	79	44	95	66	8-M8
XL5	450	8000	14~55	50	95	140	75	94	26	3	88	50	115	80	12-M8
XL6	525	7100	15~60	56	105	150	85	104	28	3.5	96	52	125	90	12-M8
XL7	685	6300	20~70	65	120	175	98	118	30	4	111	62	145	102	8-M10
XL8	940	5600	22~75	75	135	190	115	134	35	4.5	126	67	160	116	12-M10
XL9	1920	4750	30~90	85	160	215	135	158	40	5	144	78	185	136	15-M12
XL10	3600	3750	40~100	100	200	260	160	180	45	5.5	165	85	225	172	15-M16
XL11	4950	3350	50~110	110	225	285	180	200	50	6	185	100	250	195	15-M16
XL12	7200	3000	60~125	120	255	330	200	230	55	6.5	201	107	290	218	12-M20
XL13	10000	2650	60~145	140	290	370	230	265	60	7	230	120	325	252	15-M20
XL14	12800	2360	60~165	155	320	410	256	300	65	7.5	254	133	360	282	15-M20
XL15	19200	2000	80~190	175	370	460	290	345	75	9	288	151	410	325	15-M24
XL16	28000	1800	85~220	195	420	520	325	400	85	10.5	320	165	465	375	18-M24

XLDF(XLSF)单(双)法兰带轴套星形弹性联轴器
 XLDF(XLSF) star coupling with single of double flange shaft sleeve

◇ 标记 Mark



◇ 结构特点

- 适用于重型机械的法兰连接
- 拆下法兰就可径向安装，非常方便
- 对于SF型，不必移动主动端及从动端设备进行弹性体更换
- 安装时需切断动力

◇ Design feature

- Apply for flange connect in heavy machine.
- It can be easily radial fitted with unload the flange.
- As for SF type the spider can be changed without move the equipments on drive and driven end.
- Please cut the power when installing.

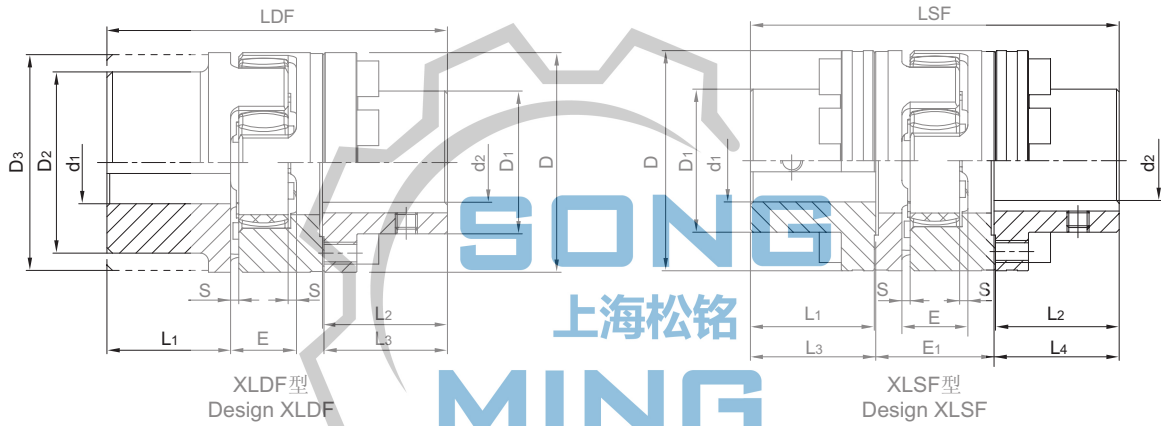

◇ XLDF、XLSF型带法兰星形弹性联轴器基本参数和主要尺寸

Base figure and main size of XLDF、XLSF star coupling with single or double flange shaft sleeve

型号 Type	公称扭矩 Nominal torsion N.m	许用转速 Limited rotational speed r/min	轴孔直径 Diameter of the shaft hole d1、d2mm	D	D1	D2	D3	E	E1	S	L1 (L2)	L3 (L4)	LDF	Lsf	
				(mm)											
XLDF2	XLSF2	60	14000	8-24	55	36	40	55	18	33	2	30	30.5	86	94
XLDF3	XLSF3	160	11800	8-28	65	42	48	65	20	39	2.2	35	35.5	100	110
XLDF4	XLSF4	325	9500	10-38	80	52	66	78	24	43	3	45	45.5	124	134
XLDF5	XLSF5	450	8000	10-42	95	62	75	94	26	48	3	50	51.0	138	150
XLDF6	XLSF6	525	7100	10-48	105	70	85	104	28	50	3.5	56	57.0	152	164
XLDF7	XLSF7	685	6300	15-55	120	80	98	118	30	60	4	65	66.0	176	192
XLDF8	XLSF8	940	5600	15-65	135	94	115	134	35	65	4.5	75	76.0	201	217
XLDF9	XLSF9	1920	4750	20-75	160	108	135	158	40	75	5	85	86.5	229	248
XLDF10	XLSF10	3600	3750	30-90	200	142	160	180	45	82	5.5	100	101.5	265	285
XLDF11	XLSF11	4950	3350	30-115	225	158	180	200	50	97	6	110	111.5	295	320
XLDF12	XLSF12	7200	3000	40-125	255	178	200	230	55	103	6.5	120	122.0	321	347
XLDF13	XLSF13	10000	2650	40-145	290	206	230	265	60	116	7	140	142.0	370	400
XLDF14	XLSF14	12800	2360	40-160	320	235	256	300	65	128	7.5	155	157.5	409	443
XLDF15	XLSF15	19200	2000	40-180	370	270	290	345	75	146	9	175	177.5	463	501
XLDF16	XLSF16	28000	1800	85-2000	420	315	325	400	85	159	10.5	195	198.0	515	555

ML 梅花形弹性联轴器
ML plum blossom type elastic shaft coupling

◇概述

梅花形弹性联轴器是由两个带凸爪形状相同的半联轴器和弹性元件组成，利用梅花形弹性元件置于两半联轴器凸爪牙之间，以实现两半轴器的联接。具有补偿两轴相对偏移，减振，缓冲，径向尺寸小，结构简单，不用润滑，承载能力较高，维护方便等特点，但更换弹性元件时两半联轴器需沿轴向移动。适用于联接两同轴线，起动频繁，正反转变换，中低速中小功率，传动轴系，要求工作可靠性高的场合，不适用于重载及轴向尺寸受限制，更换弹性元件后两轴线对中困难的场合。

◇标记示例 The mark gives a demonstration

ML4型梅花形弹性联轴器

主动端：Z型轴孔，C型键槽，轴孔直径d1=35mm，轴孔长度L=62mm

从动端：Y型轴孔，B型键槽，轴孔直径d2=24mm，轴孔长度L=65mm

◇标记方法

联轴器(Shaft coupling)ML4 $\frac{ZC35 \times 62}{YB24 \times 65}$ GB/T5272-2002

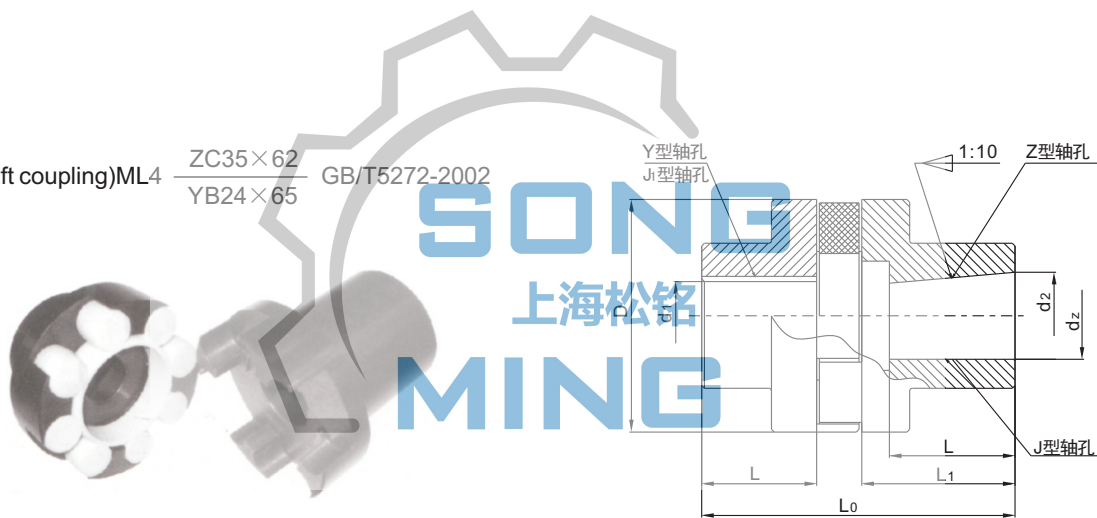

ML 梅花形弹性联轴器
ML plum blossom type elastic shaft coupling

◇ML型梅花形弹性联轴器的基本参数及主要尺寸(GB/T5272-2002)

Base figure and main size of ML plum blossom type elastic shaft coupling (GB/T5272-2002)

型号 Type	公称扭矩 N.m Nominal torsion			许用转速 Limited rotational speed(rpm)		轴孔直径mm d1.d2.dz Diameter of the shaft hole	轴孔长度 mm Length of the shaft hole		L0 mm	D mm	许用补偿量 Limited compensation			转动惯量 Rotate inertia kg.m ²	重量 Weight kg
	弹性体硬度 Hardness of Elastomer						Y型 Type	Z,J型 Type			轴向 Axial	径向 Radial	角向 Angle		
	shA	shB	shD	L	L										
	80±5	92±5	60±5	铁 Iron	钢 Steel		mm								
ML1	16	25	45	11500	15300	12.14	32	27	80	50	1.2	0.5	2.0	0.014	0.66
						16.18.19	42	30	100						
						20.22.24	52	38	120						
ML2	63	100	200	8200	10900	20.22.24	52	38	127	70	1.5	0.8	2.0	0.075	1.55
						25.28	62	44	147						
						30.32	82	60	187						

ML 型梅花形弹性联轴器
ML claw elastic shaft coupling

◇ ML 型梅花形弹性联轴器的基本参数及主要尺寸(GB/T5272-2002)
Base figure and main size of ML plum blossom type elastic shaft coupling(GB/T5272-2002)

型号 Type	公称扭矩 N.m Nominal torsion			许用转速 Limited rotational speed(rpm)		轴孔直径mm d1.d2.dz Diameter of the shaft hole	轴孔长度mm Length of the shaft hole		L0 mm	D mm	许用补偿量 Limited compensation			转动 惯量 Rotate inertia kg.m ²	重量 Weight kg
	弹性体硬度 Hardness of Elastomer						Y型 Type	Z,J型 Type			轴向 Axial	径向 Radial	角向 Angle		
	shA	shB	shD	L	L										
	80±5	92±5	60±5	铁 Iron	钢 Steel		mm								
ML3	90	140	280	6700	9000	22.24	52	38	128	85	2.0	0.8	2.0	0.178	2.5
						25.28	62	44	148						
						30.32.35.38	82	60	188						
ML4	140	250	400	5500	7300	25.28	62	44	151	105	2.5	0.8	2.0	0.412	4.3
						30.32.35.38	82	60	191						
ML5	250	400	710	4600	6100	30.32.35.38	82	60	197	125	3.0	1.0	1.5	0.73	6.2
						40.42.45.48	112	84	257						
ML6	400	630	1120	4000	5300	30*.38*	82	60	203	145	3.0	1.0	1.5	1.85	8.6
						40*.42*.45.48.50.55	112	84	263						
ML7	710	1120	2240	3400	4500	45*.48*.50.55	112	84	265	170	3.5	1.0	1.5	3.88	14.0
						60.63.65	142	107	325						
ML8	1120	1800	3550	2900	3800	50*.55*	112	84	272	200	4.0	1.5	1.5	9.22	25.7
						60.63.65.70.71.75	142	107	332						
ML9	1800	2800	5600	2500	3300	60*.63*.65*.70.75	142	107	334	230	4.5	1.5	1.0	18.95	41.0
						80.85.90.95	172	132	394						
ML10	2800	4500	9000	2200	2900	70*.71*.75*	142	107	344	260	5.0	1.5	1.0	39.68	59.0
						80*.85*.90*.95*	172	132	404						
						100.110	212	167	484						
ML11	4000	6300	12500	1900	2500	80*.85*.90*.95*	172	132	411	300	5.0	1.8	1.0	73.43	87.0
						100.110.120	212	167	491						
ML12	7100	11200	20000	1600	2100	90*.95*	172	132	417	360	5.0	1.8	1.0	178.45	140
						100*.110*.120*.125*	212	167	497						
						130	252	202	577						
ML13	8000	12500	25000	1400	1900	100*.110*.120*.125*	212	167	497	400	5.0	1.8	1.0	208.75	160
						130*.140*.150*	252	202	577						
						160	302	242	677						

注：1、轴孔直径带*号的可用于J型、Z型轴孔。

2、表中kg为联轴器总重量。

Note: 1. Shaft hole diameter with * can be use for the Model J、Z.

2. Kg in the form is the total weight of the shaft coupling.

MLS 型双法兰型梅花形弹性联轴器
MLS type claw elastic shaft coupling with double-flange

◇ 标记说明 Mark explain

对于Z型、J型带沉孔的轴孔长度是指轴孔的配合长度（即下图中L1尺寸）

AS for Z and J type coupling with counterbore hole length is length of fit (as the datas in down drawings)

◇ 标记示例 The mark gives a demonstration

MLS3型梅花形弹性联轴器

MLS3 type claw flexible couplings

MT3a弹性件硬度为shA80

The hardness of MT3a spider is shA80

主动端：Z型轴孔，C型键槽，轴孔直径 $d_z=30$
轴孔长度 $L=60$ (不含沉孔长度)

Drive end Z type shaft hole. C type key way diameter of shaft hole d_z is 30mm
Length of shaft hole L is 60mm (counterbore is not included)

从动端：Y型轴孔，B型键槽，轴孔直径 $d_2=25$
轴孔长度 $L=62$

Driven end Y type shaft hole. B type key way, shaft hole diameter d_2 is 25mm
Length of shaft hole L is 62mm

MLS3联轴器 $Zc30 \times 60$ MT3a GB/T5272-2002
 $B25 \times 62$

Marked as: MLS3 $Zc30 \times 60$ MT3a GB/T5272-2002
 $B25 \times 62$

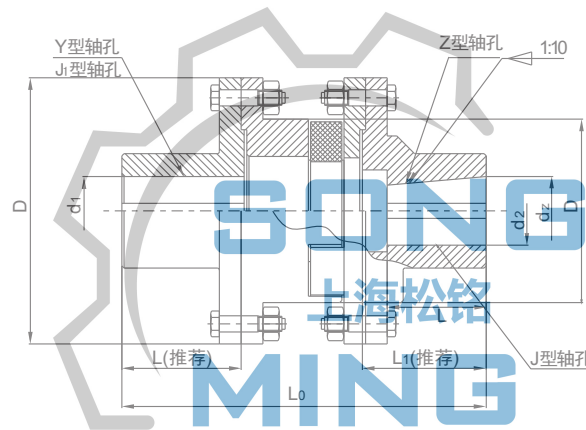

MLS 型双法兰型梅花形弹性联轴器
MLS type claw elastic shaft coupling with double-flange

◇ MLS型双法兰型梅花弹性联轴器基本参数和主要尺寸(GB/T5272-2002)

Base figure and main size of MLS type claw elastic shaft coupling with double-flange (GB/T5272-2002)

型号 Type	公称扭矩 N.m Nominal torsion		许用转速 Limited rotational speed rpm	轴孔直径 Diameter of the shaft hole $d_1.d_2.d_3$ mm	轴孔长度 mm Length of the shaft hole		L、L1 推荐 Commend mm	L0 mm	D mm	D1 mm	弹性件 型号 Spider type	质量 quality m/kg	转动惯量 Rotate inertia kg.m ²
	弹性件硬度 Nominal torsion				Y型	J1、J、Z型							
	a/shA	b/shD											
	80±5	60±5			L	L							
MLS1	25	45	8500	12.14	32	27	35	98	50	90	MT1 ^a _b	1.33	0.0013
				16.18.19	42	30							
				20.22.24	52	38							
				25	62	44							
MLS2	100	200	6900	20.22.24	52	38	40	117	70	110	MT3 ^a _b	2.33	0.0034
				25.28	62	44							
				30.32	82	60							
MLS3	140	280	6200	22.24	52	38	45	130	85	125	MT4 ^a _b	3.38	0.0064
				25.28	62	44							
				30.32.35.38	82	60							
				40	112	84							

MLS 型双法兰型梅花形弹性联轴器
MLS type claw elastic shaft coupling with double-flange

◇MLS型双法兰型梅花弹性联轴器基本参数和主要尺寸(GB/T5272-2002)

Base figure and main size of MLS type claw elastic shaft coupling with double-flange(GB/T5272-2002)

型号 Type	公称扭矩 N.m Nominal torsion		许用转速 Limited rotational speed rpm	轴孔直径 Diameter of the shaft hole d1.d2.dz mm	轴孔长度 mm Length of the shaft hole		L、L1 推荐 Commend mm	L0 mm	D mm	D1 mm	弹性件 型号 Spider type	质量 quality m/kg	转动 惯量 Rotate inertia kg.m ²
	弹性件硬度 Nominal torsion				Y型	J1、J、Z型							
	a/shA	b/shD											
	80±5	60±5			L	L							
MLS4	350	400	5000	25.28	62	44	50	150	105	150	MT5 ^{-a} _{-b}	6.07	0.0175
				30.32.35.38	82	60							
				40.42.45	112	84							
MLS5	400	710	4100	30.32.35.38	82	60	55	167	125	185	MT6 ^{-a} _{-b}	10.47	0.0444
				40.42.45.48	112	84							
MLS6	630	1120	3700	35*.38*	82	60	60	185	145	205	MT7 ^{-a} _{-b}	14.22	0.0739
				40*.42*.45.48.50.55	112	84							
MLS7	1120	2240	3100	45*.48*.50.55.56	112	84	70	209	170	240	MT8 ^{-a} _{-b}	21.16	0.1493
				60.63.65	142	107							
MLS8	1800	3550	2800	50*.55*.56*	112	84	80	240	200	270	MT9 ^{-a} _{-b}	30.70	0.2767
				60.63.65.70.71.75	142	107							
				80	172	132							
MLS9	2800	5600	2500	60*.63*.65*.70.71.75	142	107	90	268	230	305	MT10 ^{-a} _{-b}	44.55	0.5262
				80.85.90.95	172	132							
				100	212	167							
MLS10	4500	9000	2200	70*.71*.75*	142	107	100	308	260	350	MT11 ^{-a} _{-b}	70.72	1.1362
				80*.85*.90.95	172	132							
				100.110.120	212	167							
MLS11	6300	12500	1900	80*.85*.90*.95*	172	132	115	345	300	400	MT12 ^{-a} _{-b}	99.54	1.9998
				100.110.120.125	212	167							
				130	252	202							
MLS12	11200	20000	1600	90*.95*	172	132	125	373	360	460	MT13 ^{-a} _{-b}	137.53	3.6719
				100.110.120.125	212	167							
				130	252	202							
MLS13	12500	25000	15000	100*.110*.120*.125*	212	167	135	383	400	500	MT14 ^{-a} _{-b}	165.25	5.1581
				130.140.150	252	202							
				160	302	242							

- 1、质量、转动惯量按L推荐最小轴孔计算近似值。
- 2、带*号轴孔直径可用于Z型、J型轴孔。
- 3、a、b为二种材料的硬度代号
- 4、L0是两端轴孔长度均为L推荐时联轴器的全长
- 5、Y型为长圆柱形轴孔，J1型为无沉孔为短圆柱形轴孔，J型为有沉孔短圆柱形轴孔，Z型为有沉孔的圆锥形轴孔。

LMZ-I型带制动轮梅花形弹性联轴器
LMZ-I type claw elastic shaft coupling

◇ 标记示例(Mark sample): LMZ12-I-630YA110×115/Zc95×115

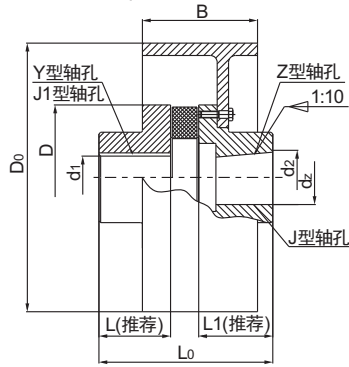

◇ LMZ-I型带制动轮梅花形弹性联轴器基本参数和主要尺寸 (GB/T5272-2002) /mm
Base figure and main size of LMZ-I、MLZ-I type claw elastic shaft coupling(GB/T5272-2002)/mm

型号 Type	公称扭矩 N.m Nominal torsion		许用转速 Limited rotational speed rpm	轴孔直径 Diameter of the shaft hole d1,d2,dz		L (推荐) Commend	L ₀	D ₀	B	D	弹性件 型号 Spider type	重量 weight kg	转动惯量 Rotate inertia I/kg.m ²
	弹性件硬度 Spider type hard ness												
	a/shA	b/shD											
	80±5	60±5											
LMZ5-I-160	250	400	4750	25.28.30.32.35.38	40.42.45	50	127	160	70	105	MT5 ^{-a} _{-b}	6.602	0.019
LMZ5-I-200				25.28.30.32.35.38	40.42.45							9.204	0.044
LMZ6-I-200	400	710	3800	30.32.35.38.40	42.45.48	55	143	200	85	125	MT6 ^{-a} _{-b}	11.45	0.052
LMZ7-I-200	630	1120		35*.38*.40*.42*	45.48.50.55.56							60	159
LMZ7-I-250			35*.38*.40*.42*	45.48.50.55.56	20.09	0.144							
LMZ8-I-250	1120	2240	3050	45*.48*.50.55.56	60.63.65	70	181	250	105	170	MT8 ^{-a} _{-b}	24.65	0.175
LMZ8-I-315				45*.48*.50.55	56.60.63.65							34.13	0.374
LMZ9-I-315	1800	3550	2400	50*.55*.56*.60.63	65.70.71.75.80	80	208	315	135	200	MT9 ^{-a} _{-b}	41.67	0.45
LMZ9-I-400				50*.55*.56*.60.63	65.70.71.75.80							65.61	1.259
LMZ10-I-400	2800	5600	1900	60*.63*.65*.70.71	75.80.85.90.95.100	90	230	400	170	230	MT10 ^{-a} _{-b}	74.53	1.4
LMZ10-I-500				60*.63*.65*.70.71	75.80.85.90.95.100							110.6	3.427
LMZ11-I-500	4500	9000	1500	70*.71*.75*.80*.85*	90.95.100.110.120	100	260	500	210	260	MT11 ^{-a} _{-b}	121.7	3.715
LMZ12-I-630	6300	12500		80*.85*.90*.95*	100.110.120.125.130							115	297
LMZ13-I-710	11200	20000	1050	90*.95*.100*.110*.120*	125*.130.140.150	125	323	710	300	360	MT13 ^{-a} _{-b}	341.6	19.99
LMZ14-I-800	12500	25000		950	100*.110*.120*.125*							130*.140*.150.160	135

注：1、质量、转动惯量是按材料为铸钢、L_{推荐}、最大轴孔计算的近似值
2、带*号轴孔直径可用于Z、J型轴孔。
3、a、b为两种弹性材料硬度代号。