



上海松铭传动机械有限公司
SHANGHAI SONGMING TRANSMISSION MACHINERY CO.,LTD



公司简介 | Company brief introduction

上海松铭传动机械有限公司是一家研究、设计、销售机械传动类产品的公司，供应产品有：WS/WSD/WSS/WSP万向节、SWP/SWC万向联轴器、ML梅花弹性联轴器、XL/XLD星型弹性联轴器、DJM/JMII/SJM/JMIIJ/ZJM弹性膜片联轴器、TL弹性柱销套联轴器、HL弹性柱销联轴器、ZL柱销齿式联轴器、制动轮式联轴器、铝合金联轴器、UL/LLA/LLB轮胎联轴器、SL十字滑块联轴器，KC/GL链条联轴器、JS蛇型弹簧联轴器、鼓型齿联轴器、凸缘联轴器、JQ夹壳联轴器、WH/SL滑块联轴器、联轴器配件（弹性体/轮胎体/铝合金外罩壳/联轴器膜片组/联轴器弹簧等）、Z型胀紧联结套及SPA/SPB/SPC/SPZ锥套皮带轮等产品，并承接非标传动零部件的定制加工。

产品咨询订购电话：18621008099

联轴器系列

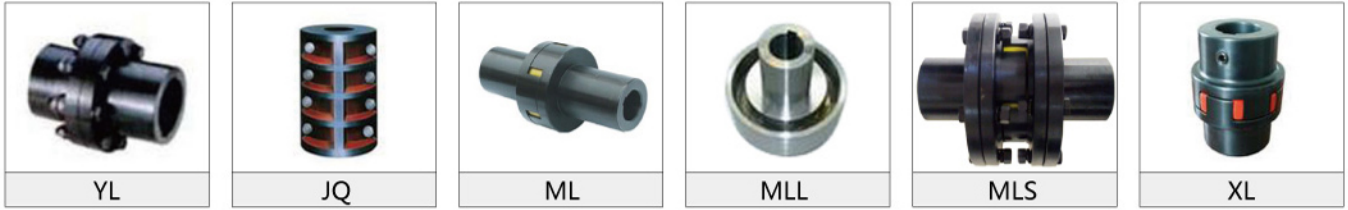

联轴器系列



常用联轴器孔和键槽形式 Mode of hole and key way form of normal couplings

◇ 摘自GB/T3852-1997 《联轴器轴孔和联结型式及尺寸》
The model and marks from GB/T3852-1997 《sizes mode of hole and connecting of coupling》

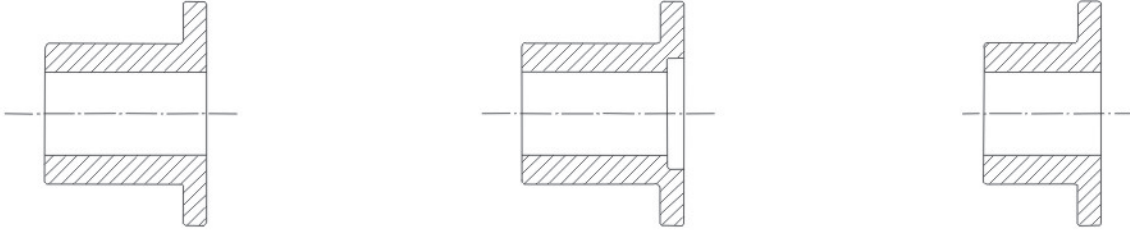

1、Y型长圆柱形轴孔
(限于长圆柱形轴伸电机端)
1. Y type long ring shaft hole
(Only apply for electrical machine
ends of long open ring shaft)

2、J型有沉孔的短圆柱形轴孔
(推荐选用)
2. J type cylindrical shaft hole
with counterbore(commending)

3、J1型无沉孔的短圆柱形轴孔
(推荐选用)
3. J1 type short cylindrical shaft
hole without counterbore
(commending)



4、Z型有沉孔的圆锥形轴孔
4. Z type coniform shaft hole with counterbore

5、Z1型无沉孔的圆锥形轴孔
5. Z1 type coniform shaft hole without counterbore

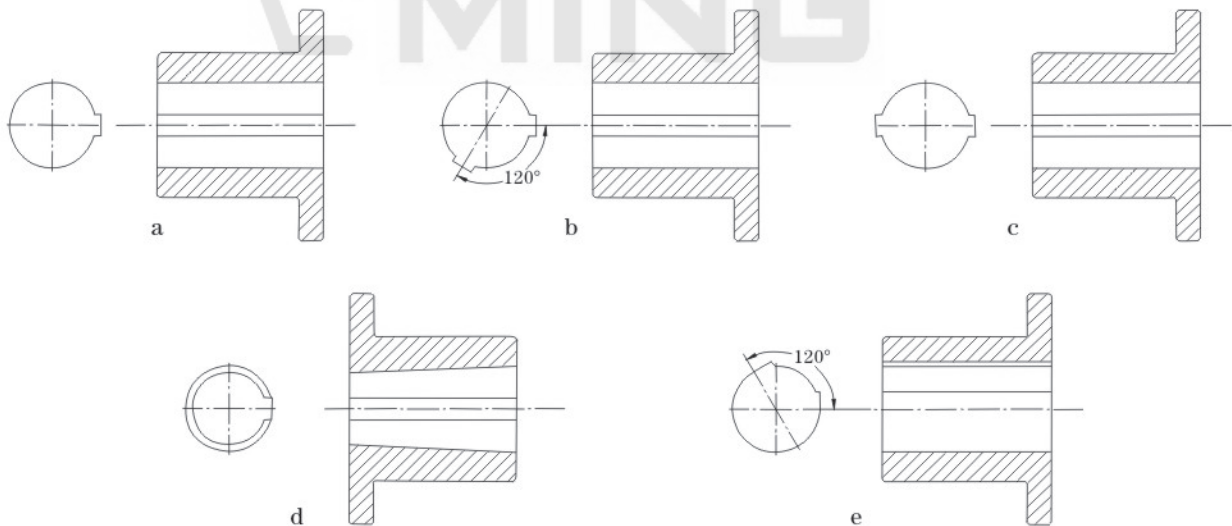

键槽形式keyway modes

(a)A型平键单键槽；(b)B型120°布置平键双键槽；(c)B1型布置平键双键槽；(d)C型圆锥形孔平键单键槽；(e)D型普通切向键键槽。
a. A type even single keyway b. B type even double keyway with 120° display C. B1 type even double keyway
d. C type even single keyway with conic hole e. D type normal keyway with tangential key

LTZ (TLL) 型带制动轮弹性套柱销联轴器 (GB/T4323-2002)
LTZ(TLL) Type flexible coupling (with brake wheel)

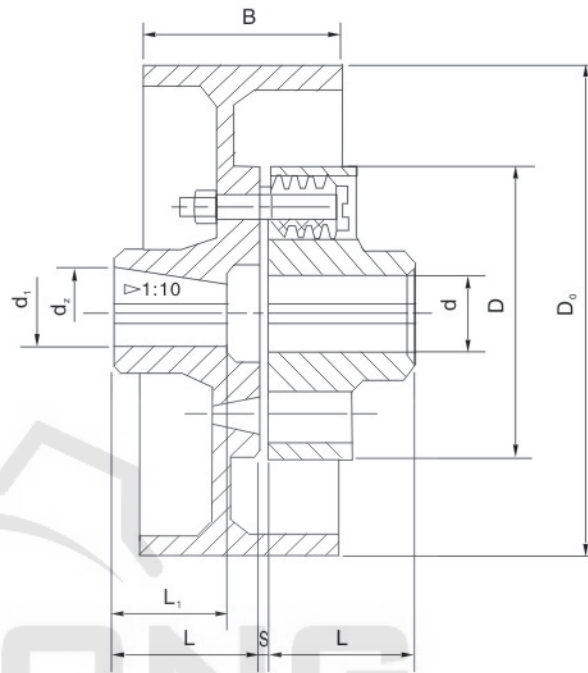

◇LTZ型联轴器主要参数与尺寸
LTZ Type coupling Main parameters.

新型号	旧型号	公称转矩 Tn N·m	许用转速 [n] r/min	轴孔直径 d, d ₁ , dz	轴孔长度		尺寸					重量 kg
					Y型	J.Z型	D ₀	B	D	S	A	
					L	L ₁						
LTZ5	TLL1	125	3800	25~35	62~82	44~82	200	85	130	5	45	13
LTZ6	TLL2	250	3000	32~42	82~112	60~112	250	105	160	5	45	21
LTZ7	TLL3	500	2400	40~48	112	84~112	315	132	190	5	45	35
LTZ8	TLL4	710	2400	45~63	112~142	84~142	315	132	224	6	65	45
LTZ9	TLL5	1000	2400	50~71	112~142	84~142	315	132	250	6	65	58
LTZ10	TLL6	2000	1900	63~95	142~172	107~172	400	168	315	8	80	100
LTZ11	TLL7	4000	1500	80~110	172~212	132~212	500	210	400	10	100	198
LTZ12	TLL8	8000	1200	100~130	212~252	167~252	630	265	475	12	130	370
LTZ13	TLL9	16000	1000	120~170	212~302	167~302	710	298	600	14	180	641